

MUSCLE CAR

2026 Rules

- *2026 SFR Region MC Addendum*
- *2018 GCR Section 9.1.6 for A Sedan*



MC – Muscle Car

(Effective Jan 1, 2026)

1. **INTENT.** Regional only class MC is formed to provide a competition class for those certain cars manufactured between 1964 and 2013, as specified In the SCCA General Competition Rules (GCR) version effective date September 1, 2018, GCR Section 9.1.6 for A Sedan Class (AS), and as shall further be added as a supplement to these rules.
2. **SAFETY.** All cars shall conform to GCR Section 9 for the current competition year for class A Sedan and/or class T2 for Restricted Prep cars.
3. **MODIFICATIONS.** All cars shall conform to the specifications listed for A Sedan in the September 1, 2018, GCR Section 9.1.6 with the following changes:
 - a. Full Prep: Maximum engine displacement shall be 358 cubic inches. Rev limiters may be imposed on any given engine configuration in order to maintain durability and/or engine parity.
 - b. Full Prep: **Any** OEM factory type roller, hydraulic flat tappet or mechanical flat tappet lifters and camshaft may be used. Maximum valve lift is .5000” measured at the valve at running valve lash.
 - c. Full Prep: Any OEM factory production iron heads meeting compression ratio, valve size and manifold rules in GCR 9.1.6 may be used.
 - d. Full Prep: General Motors cars may use Trick Flow Specialties -Trick Flow® Super 23® 175 Fast as Cast Cylinder Heads for Small Block Chevrolet. Part numbers TFS-30310001, TFS-30310002, TFS-30310003, TFS-30310004, TFS-30310004, TFS-30310005, TFS-30310006 or TFS-30310007 may be used. No modifications to cylinder head castings are allowed.
 - e. Crate Motor equipped full preparation vehicles:
 1. Full Prep: Crate engines meeting manufacturer specifications for the specific car may be used.
 2. The following “crate motors” may be utilized in Full preparation vehicles: Ford Performance M-6007-D347SR7 engine assembly for Ford produced vehicles. GM Performance parts CT400 P/N-19370604 engine assembly for GM produced vehicles.
 3. No modifications may be made to these engine assemblies except the following listed components. All replaced components must be replaced with components meeting existing full preparation rules. If components are not furnished with the “Crate Motor” assembly, all additional components must meet existing Full preparation rules:
 - i. Oil pan, oil pump and oil pump pickup.
 - ii. Connecting rods
 - iii. Valve springs
 - iv. Valve/Rocker covers
 - v. Aluminum Carburetor Spacer – Maximum Thickness of 1.00”
 - vi. Distributor assembly
 - vii. Spark plugs
 - viii. Water pump
 - ix. Thermostat
 - x. Fuel pump
 - f. Restricted Prep - GM 4.8L, 5.3L & 5.7L LS Engine Option: GM cars may use an LS based 4.8L, 5.3L or 5.7L engine long block assembly from the 1998–2002 (Gen 4) Camaro/Firebird or 1999–2006 GM trucks prepared to the Restricted Prep rule set. The intake and exhaust manifolds; and all external accessories and electronics from the Gen 4 F-Body GM 5.7L LS cars must be retained. The Gen 4 F-Body GM 5.7L air intake system or the SCCA American Sedan restricted preparation SLP airbox must be used. The OEM camshaft from the Gen 4 F-Body GM 5.7L LS1 cars or the OEM 5.3L truck camshaft must be used. Nonstock aftermarket camshafts are not allowed.
 - g. Full Prep: All gearboxes must use synchro-ring method of gear engagement. No “dog boxes” of any type are allowed. All gearboxes must have and use a 1:1 4th gear.

- h. Wheels: Maximum wheel diameter is 18". Maximum wheel width is 10.5".
- i. Tires: Tires with a minimum UTQG rating of 100 must be used. Maximum cross section is 275.
- j. A Sedan air dam/splitter specification, may be used. The A Sedan spec aftermarket fiberglass hoods may have the rear opening functional.
- k. Minimum weight for all cars with 13.10" or less diameter brakes is 3,200 pounds. Minimum weight for cars with brake diameters greater than 13.10" is 3,400 pounds.
- l. All cars shall carry the class designation MC on both sides of the car with a minimum height of 4".
- m. Rear spoilers or wings shall be as originally fitted or as specifically authorized on the specification line for that vehicle. NASA CMC spoilers and others are not allowed.
- n. Vehicles with rear trailing arms may replace OEM arms with tubular arms. Arms must maintain stock length and serve no other purpose than locating rear axle assembly. Pins, keys, or weldment may be used to prevent the rotation of alternate bushings but may serve no other purpose than that of retaining the bushing in the desired position.
- o. The installation of a fuel safety cell meeting GCR Section 9.3.26 requirements is not required but is allowed and strongly recommended.**

4. GOVERNING BODY: San Francisco Region SCCA shall be the governing and sanctioning body for MC.

5. CLASS DIRECTOR: A class director(s) shall be appointed by the San Francisco Region Competition Director at the beginning of each competition year in January. The Director(s) shall be ratified by a majority vote of class drivers with one vote each for every competitor that participated in the MC class in the prior year. It shall be the responsibility of the Director(s) to liaison with the SF Region in all matters relating to class MC. The Director(s) shall have the power to implement competition adjustments to the class throughout the year with a 30-day notice to all class participants of such adjustments.

- 2026 MC Class Directors
 - Charlie Laster: calaster@me.com
 - Darryl Seefeldt: dseefeldt@comcast.net
 - Richard Pryor: pryor1948@gmail.com

6. The Chief of Technical Inspection and the San Francisco Region Competition Director shall be supplied with the SCCA General Competition Rules (GCR) with an effective date of September 1, 2018, GCR Section 9.1.6 for A Sedan Class (AS) and the Muscle Car (MC) Supplemental Rules and Regulations by the MC Class Director(s) at least 30 days prior to the first scheduled race event of the calendar year. Additional competition adjustments to the class throughout the year shall be supplied to the Chief of Technical Inspection and the San Francisco Region Competition Director with an effective date of 30 days from given notice. Chief of Technical Inspection shall cause a copy of the September 1, 2018, GCR Section 9.1.6 for A Sedan Class (AS) and the Muscle Car (MC) Supplemental Rules and Regulations to be present at the Technical Inspection/Impound Area for each event at which the MC class participates.

2018 SCCA ROAD RACING GENERAL COMPETITION RULES

SCCA
Sports Car Club of America
WWW.SCCA.COM

TIRE RACK
.com



HAWK
PERFORMANCE

Mobil 1

CHEVROLET

MAZZA
EnjoyMazda.com

SUMMIT
RACING EQUIPMENT

9.1.6. AMERICAN SEDAN CATEGORY

These specifications are part of the SCCA GCR and all automobiles shall conform to GCR Section 9.

A. PURPOSE

The American Sedan (AS) class is intended to provide the membership with the opportunity to compete in lower cost V8 powered automobiles, suitable for racing competition. Cars eligible for this class are listed at the end of 9.1.6. They will be prepared to manufacturer's specifications except for modifications and alternate specifications permitted by these rules. Modifications will be grouped into two categories, "Full" preparation and "Restricted" preparation. All modifications will specify the category to which they apply. The Club may alter or adjust certain specifications to equate competitive potential.

B. INTENT

It is the intent of these rules to allow modifications useful and necessary to construct a safe, more reliable, competition automobile. Other than those items specifically allowed by these rules, no component or part normally found on a stock example of a given vehicle shall be disabled, altered, or removed. Cars need not be eligible for state licensure or registration.

1. The competitiveness of any car in American Sedan shall not be guaranteed.

Restricted Preparation Cars Only: Restricted Preparation American Sedan automobiles shall, at all times, be in compliance with the specifications contained within their factory Shop/Service Manual(s) except as modified by these rules. Factory Shop/Service Manuals may come in the form of printed material, microfiche, CDs, DVDs and/or Internet access to manufacturer sponsored web-based databases. It is the responsibility of the competitor to provide this information upon request from any SCCA official and to provide the electronic device capable of accessing the data for compliance verification. Failure to provide some form of the Factory Shop/ Service Manual upon request is adequate for disqualification from any event.

C. SPECIFICATIONS

1. To maintain the restricted basis of American Sedan, updating and/or backdating of components is only permitted within cars of the same make/model and listed on a single American Sedan Specification line. Any updated/backdated components shall be substituted as a complete assembly. No interchange of parts between assemblies is permitted, and all parts of an assembly shall be as originally produced for that assembly. No permitted or alternate component or modification shall additionally perform a prohibited function.
2. Cars are classified by year, make, model and/or engine displacement (see Section E., "Car Classification").
 - a. Restricted Preparation American Sedan cars must provide their Vehicle Identification Number (VIN), upon request from any SCCA official, for the purpose of identifying the year in which the car was built. The VIN number shall not be used for any other purpose.
3. The SCCA shall specify the minimum weight for each classified car, as qualified or raced, with driver. Ballast is permitted.
4. Cars potentially eligible for Restricted Preparation may be required to run in Touring for at least two years before being classified in American Sedan. Cars not classified in Touring will be considered, on an individual basis, when adequate information is available to determine correct specifications.
5. Where Factory Specifications are absent or unclear, SCCA may establish an acceptable dimension and/or tolerance from known stock parts.
6. All rules referencing OEM parts, unless specified in these rules, must be unmodified OEM parts.

D. AUTHORIZED MODIFICATIONS

The following modifications are authorized on American Sedan Category cars. It is not permitted to make changes, alterations, or modifications to any component produced by the manufacturer unless specifically authorized by these rules, or required by the GCR. No permitted or alternate component or modification shall additionally perform a prohibited function. Replacement parts may be obtained from sources other than the manufacturer provided they are exact equivalent of the original parts. The intent of this rule is to allow the competitor to obtain replacement parts from standard industry outlets, such as, auto parts distributors, rather than from the manufacturer. It is not intended to allow parts that do not meet all dimensional and material specifications of new parts from the manufacturer, unless otherwise allowed in these rules.

1. Engine (additional specs., see Section F – Engine Build Sheets)
 - a. Air Induction System:
 1. Full preparation cars only:
 - a. All cars shall fit the approved carburetor and manifold. The approved manifold may be ported and polished, and exhaust crossover may be blocked, but its design and configura-

9.1.6. American Sedan (AS) Specifications

tion shall not be altered in any other way. The lowering of or boring of holes in the center divider is prohibited. Removal or obliteration of the manifold part number is prohibited.

- b. Any external throttle linkage to the carburetor may be used. Choke mechanisms, plates, rods, and actuating cables, wires, or hoses may be removed. No removal or alteration of the carburetor air horn is permitted.
- c. All air entering the intake tract shall pass through the carburetor air inlet.
- d. An open-sided, closed-top air cleaner assembly, with a maximum diameter of 16 inches, with a filter element having a maximum diameter of 14 inches and a maximum height of 3 inches is required.
- e. Filter element material is unrestricted.
- f. Velocity stacks, ram air, cowl induction, shrouding or ducting of air to the air cleaner or carburetor are not permitted.

2. Restricted preparation cars only:

- a. All unmodified OEM induction system components (such as, but not limited to: air cleaner assembly (less filter element), all hoses connecting the air cleaner assembly to the throttle body, throttle body, and intake manifold) must be maintained. All air entering the intake tract shall enter through the OEM throttle body.
- b. Non OEM Cold air induction systems are prohibited unless indicated on specification line.
- c. Air filter element material is unrestricted.
- d. Restrictor plates may be required. Refer to vehicle specification line.

b. Fuel Pumps/Lines:

1. Any fuel pump(s), fuel pressure regulators, or filters may be used and may be relocated, but shall not be located in the driver/passenger compartment. If a mechanical pump is removed, a blanking plate may be used to cover the original mounting location.
2. Fuel line(s) may be replaced, relocated, and given additional protection. If the relocated line(s) passes through the driver/passenger compartment, it/they shall be metal or metal braided, and shall be securely fastened.

c. Fuel Delivery:

1. Full preparation cars only:

- a. Only the approved carburetor (Holley #4776, 600cfm 4bll), insulator (Holley #108-12), and manifold (Edelbrock Performer RPM #7101-General Motors / #7121- Ford/Mercury) shall be fitted to cars. The carburetor shall be identified by the numbers "4776". Additional numbers stamped on the horn section of the carburetor, such as "-X" (indicating the die lot number for that carburetor) and "XXXX" (up to 4 digits indicating the day of the year the carburetor was produced along with the year in the decade it was produced) shall not be used to identify the carburetor. Two carburetor base gaskets (each base gasket can be no thicker than .125 inches) may be used, one on each side of the insulator.
- b. Other than as provided for in these rules, the carburetor shall not be modified in any way. Any carburetor jets, air jets, accelerator pump, pump cam, and accelerator pump nozzles may be used. Any power valves, metering blocks, and floats may be used. No venturi (including secondary or auxiliary) shall be modified in any way, but they may be aligned. Idle holes may be drilled in the throttle plates (butterflies). Any butterfly attach screws can be used. Carburetors may be modified to allow "four corner" idle adjustment. A Holley 600 carburetor test gauge kit, such as, BLP Racing Products Kit 7862 (with the exception of Combined Throttle Shaft and Plate gauges 78623P and 78623S), may be used to validate compliance of the carburetor (Note that the SCCA may use other kits not listed here, visual inspection, and comparison to SCCA supplied Holley 600 carburetors). Vent tubes may be modified or replaced and must be no taller than 2.0" when measured from the circular air cleaner mounting surface on the carburetor to the top most part of the tubes. The vent tubes shall not pass through the air cleaner. The vent tubes shall not be connected to each other.

Boosters must be shaped as shown fig. g below:

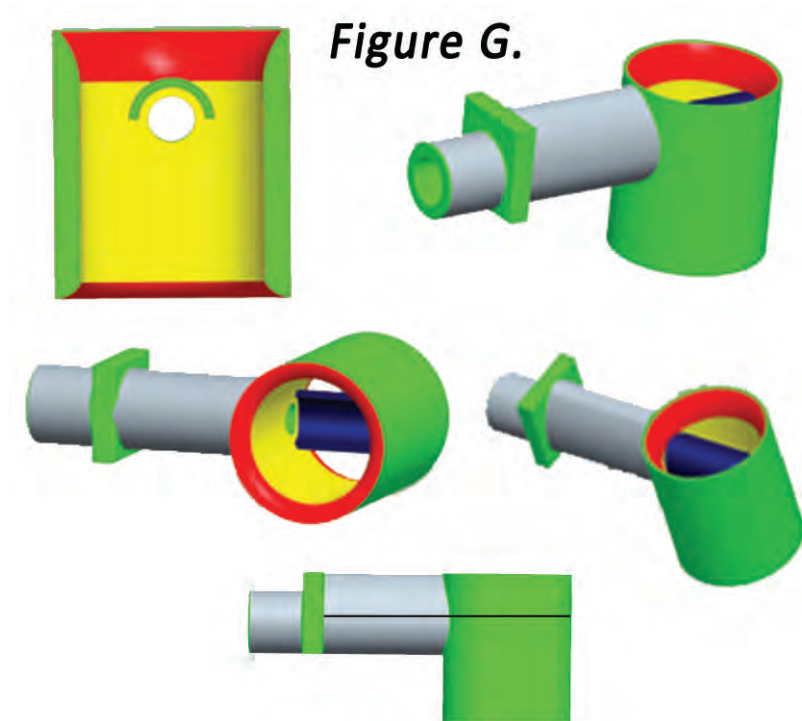

Note: black line represents a casting line that should be present.

2. Restricted preparation cars only:
 - a. OEM fuel injectors and fuel rail assembly must be maintained. To reduce fuel fire hazard, OEM fuel rail inlet and outlet (return) ports may be changed to allow alternate fittings. No other changes to the OEM fuel rail assembly are permitted.
 - b. The engine management computer or ECU may be altered but not replaced. All modifications shall be done within the original housing. ECUs must be able to communicate through the stock OBD reader port.
- d. Exhaust emission control:
 1. A.I.R. (Air Injection Reaction) pumps, associated lines, nozzles, and other electrical/mechanical emission devices may be removed. If such items are not removed, they shall not be modified in any way. If EGR devices/nozzles are removed from a cylinder head or manifold, any holes remaining shall be completely plugged.
 2. Catalytic converter(s) may be removed.
- e. Exhaust:
 1. Full preparation cars only:
 - a. Replacement exhaust manifolds, or "headers," may be used. Cylinder head mounting flange(s) shall be no thicker than 0.375 inch, and tubing diameter shall be no greater than 1.625 inch O.D., measured at any tube location one (1) inch from the flange to the collector.
 - b. Exhaust after the manifolds/headers must meet the below requirements but is otherwise unrestricted.
 1. No exhaust pipe(s) shall pass over the engine, bellhousing, or transmission.
 2. Exhaust shall exit behind the driver, and shall be directed away from the car body. A suitable exhaust muffling system may be necessary to meet sound control requirements.
 2. Restricted preparation cars only:
 - a. OEM exhaust manifolds must be maintained unless indicated on a specification line.

9.1.6. American Sedan (AS) Specifications

- b. Oxygen sensors may be removed and plugged.
- c. Exhaust after the manifolds must meet the below requirements but is otherwise unrestricted.
 - 1. No exhaust pipe(s) shall pass over the engine, bellhousing, or transmission.
 - 2. Exhaust shall exit behind the driver, and shall be directed away from the car body. A suitable exhaust muffling system may be necessary to meet sound control requirements.
- f. Ignition System:
 - 1. Full preparation cars only:
 - a. Any ignition system which utilizes the distributor for spark timing and distribution is permitted. Any distributor that requires no modification to the engine may be fitted. Internal distributor components and distributor cap may be substituted.
 - b. Crank fire ignition systems are prohibited.
 - c. Any spark plugs, single coil, and ignition wires may be used.
 - d. Ignition timing is unrestricted.
 - 2. Restricted preparation cars only:
 - a. OEM or factory equivalent ignition system must be utilized for detection and distribution.
 - b. OEM or factory equivalent coils must be utilized.
 - c. Any spark plugs and ignition wires may be used.
 - d. Ignition timing is unrestricted.
- g. Battery:
 - 1. Any 12 volt battery may be used.
 - 2. The battery may be relocated as per GCR section 9.3 Batteries.
 - 3. Additional battery hold down devices may be used, and are strongly recommended.
- h. Camshaft/Valvetrain:
 - 1. Full preparation cars only:
 - a. The camshaft may be replaced with a unit of any origin meeting specified maximum lift (see Section F – Engine Build Sheets), measured at the valve with zero lash.
 - b. Cam timing, timing chains, woodruff keys, dowel pins, and sprockets are unrestricted. Double row chains may be substituted for single row chains. Timing belts and gear driven timing systems are prohibited unless fitted as original equipment.
 - c. Valve lifters shall be of the solid (flat tappet) type only. Roller, hydraulic, or “mushroom” lifters are prohibited. See Section F – Engine Build Sheets for additional specifications.
 - d. Valve springs are unrestricted except that they shall be made of steel. Heads may be machined to accommodate any valve spring. Valve spring retainers and keepers are unrestricted.
 - e. Rocker arms may be replaced with any rocker arm. Shaft mounted rocker arms are permitted using a minimum of eight shafts. Valve train stud girdles are allowed.
 - f. Pushrods may be replaced with any pushrods of steel (ferrous) material.
 - g. Valve covers are unrestricted.
 - 2. Restricted preparation cars only:
 - a. OEM camshaft and valvetrain components must be utilized based on vehicle year and model. Updating and/or backdating within a specification line is permitted.
 - b. All camshaft/valvetrain hardware shall be installed/timed in conformance with those specifications and procedures outlined by the vehicle’s manufacturer.
 - c. Alternate camshafts may be specified for performance equity. See specification line.
 - d. Valve covers are unrestricted.
- i. Oiling system:

1. Oil pans, pan baffles, scrapers, and windage trays, oil pickups, lines, and filters are unrestricted.
 2. A pressure accumulator/"Accusump" may be fitted.
 3. The location of the filter and accumulator are unrestricted, but they shall be securely mounted within the bodywork.
 4. All oil lines that pass into or through the driver/ passenger compartment shall be metal or metal braided hose.
 5. Engine oil and oil additives are unrestricted.
 6. Oil catch tanks are permitted. All engine breathers or vapor recirculation lines, if disconnected, shall vent to a catch tank of one (1) quart minimum capacity. Such catch tanks shall not be mounted in the driver/passenger compartment.
- j. Accessory Drive:
1. Full preparation cars only:
 - a. Engine drive belts and pulleys may be replaced with any non-tooth driven belt and appropriate pulleys for the purpose of component RPM reduction.
 - b. Any mechanical (non-electrical) water pump may be used provided it is mounted in the original position.
 - c. Any belt driven, mechanical power steering pump and any alternator may be used. They must mount to the front of the engine. Remote reservoirs maybe added.
 - d. Any power steering and/or alternator brackets may be used if they perform the same mounting function as the originals.
 - e. Air conditioning systems may be removed in whole or in part.
 2. Restricted preparation cars only:
 - a. Engine drive belts and pulleys may be replaced with any non-tooth driven belt and appropriate pulleys for the purpose of component RPM reduction.
 - b. OEM or factory equivalent alternator, power steering pump and water pump may be used for repair purposes.
 - c. Air conditioning systems may be removed in whole or in part.
- k. Engine Components:
1. Full preparation cars only:
 - a. Engine block shall be cast iron as produced by the vehicle's manufacturer and must meet the requirements in Section F – Engine Build Sheets.
 - b. Main cap girdles may be fitted.
 - c. Any aluminum replacement piston with three piston rings may be used. See Section F – Engine Build Sheets for additional specifications.
 - d. Piston rings are unrestricted.
 - e. Balancing and "blueprinting" of the engine assembly are permitted. Lightening of parts beyond the minimum material removal necessary to balance is prohibited.
 - f. An alternate, commercially available, vibration dampener may be fitted.
 - g. Cylinder head to intake/exhaust manifold port matching is permitted. No material shall be removed from *or added to* the cylinder head(s) further than one (1) inch in from the manifold to cylinder head mounting face(s). External dimensions of the cylinder head or intake/exhaust manifold shall not be reduced to facilitate internal porting. *Cutting (and subsequent welding of) the intake manifold to facilitate internal porting is not permitted.*
 - h. The throat area of the port consists of a single cut up to a maximum 90 degree angle at the very bottom of the steel valve seat as it transitions to the aluminum or cast iron casting below ("Throat Cut"). It is permitted to plunge cut the throats in order to correct for core shift that is commonly found in many cylinder heads. This cut cannot extend further than 1.100 inches below from the top of the ferrous valve seat. There can be no tooling or machine marks in the head below this point. The area where the cut meets the floor of the cylinder head port cannot be blended by hand, machined or chemically processed to create a smooth transition at this point. No aluminum or cast iron in the bowl area (other than that specified for the plunge cut) or the ports may be removed, added or manipulated for any reason. It is understood that many heads may look slightly different from bowl to

9.1.6. American Sedan (AS) Specifications

bowl due to casting irregularities. No material may be removed or added from the short turn radius in the port. *No material shall be removed, added or manipulated in any area of the heads beyond the 1 inch in port matching. The heads shall not be blended by hand, machined or chemically processed for any reason (including, but not limited to) to create a smooth or resurfaced appearance. The heads shall not be cut (and subsequently re-welded) for any reason.* Any modification of the cylinder head beyond that permitted in this section and Section F. (Engine Build Sheets) is prohibited. See Section F – Engine Build Sheets for additional specifications. *Where possible, the SCCA will specify dimensions. The lack of dimensional specifications does not negate the restrictions outlined here with respect to the heads and intake manifold.*

- i. Valve guide material is unrestricted.
 - j. Milling of the cylinder head to increase compression ratio is permitted.
 - k. Any or all valve seats may be replaced. Valve seat material must be ferrous.
 - l. The combustion chamber may be repaired or modified in the area shown in Section F – Engine Build Sheets, Drawing 2 to repair or prevent pitting or damage between the intake and exhaust valves. For this repair or modification, it is permissible for the valve seats to contact each in the area shown in Section F, Drawing 2. This repair/modification may serve no other purpose.
 - m. Only stock, steel, or stainless steel intake and exhaust valves are permitted. Titanium or titanium alloy valves are not permitted. Valve seat specifications shall comply with Section F – Engine Build Sheets, Drawing 1. Valve length and valve stem installed height is open. Any valve seal may be used.
 - n. A valve job will consist of 3 valve angles only not including the throat cut angle. Each of these valve angles is open. The widths of the valve angles on the head and on the valve are open. The maximum diameter of the cut in each valve seat is .250 inches greater than the diameter of its valve head. All valve cuts must be concentric with the valve stem. Additional valve specifications are listed in Section F – Engine Build Sheets. Valve seat specifications shall comply with Section F – Engine Build Sheets, Drawing 1.
 - o. Aftermarket starters mounted in stock location are permitted.
 - p. Engine gaskets are unrestricted.
 - q. Motor mounts are unrestricted. Engine must remain in the original, or approved location.
2. Restricted preparation cars only:
- a. OEM engine components must be utilized based on vehicle year and model. Updating and/or backdating within a specification line is permitted. Replacement parts may be purchased from alternative standard outlets such as parts stores, provided they are equivalent of the stock OEM part.
Replacements parts include:
Pistons and rings
Bearings
Oil pump
Starter
Seals
Gaskets
 - b. OEM oversized pistons or factory equivalent may be used for repair purposes (max .040 inches over the bore size listed in vehicle's specification line allowed).
 - c. OEM oversized piston rings or factory equivalent may be used for repair purposes.
 - d. OEM oversized bearings or factory equivalent may be used for repair purposes.
 - e. Engine repair procedures shall be performed utilizing OEM procedure or Factory Service bulletins. Where Factory Service Manual measurement specifications for engine components may conflict with assembled Factory Service Manual specifications for performance (such as, but not limited to, compression ratio), the performance specifications shall be the measurement used for compliance. The SCCA strongly encourages the measurement of performance specifications after engine assembly and the adjustment to compliance, if needed, through the use of items listed in 9.1.6.D.1.k.2.a.
 - f. Balancing is allowed. Removal of material solely for the purposes of balancing is permitted.
 - g. Motor mounts are unrestricted. Engine must remain in the original location.
 - h. Maximum allowed compression ratio for all restricted preparation cars is specified in the

vehicle's specification line.

- I. Flywheel/Clutch:
 1. Full preparation cars only:
 - a. Any flywheel of stock diameter and weighing a minimum of 15.0 lbs with ring gear may be used.
 - b. Any clutch disc and pressure plate of stock diameter may be used.
 - c. Pressure plate/clutch cover assembly shall be ferrous only and shall bolt in the original stock mounting location.
 - d. Balancing of the flywheel/clutch cover assembly/pressure plate is permitted.
 - e. SFI 1.1 or 1.2 spec flywheel and clutch are allowed as long as they meet the above specifications. Method of clutch actuation is unrestricted.
 2. Restricted preparation cars only:
 - a. OEM or factory equivalent flywheel, clutch disc, pressure plate, and throwout bearing must be utilized.
 - b. OEM method of clutch actuation must be maintained. i.e. hydraulic or mechanical with concentric or lever style throwout bearing.
- m. Misc. Engine Components:
 1. All engine components not otherwise listed in these rules shall meet factory specifications for stock parts.
- n. Cleaning:
 1. Engine parts, including, but not limited to, heads, intake manifolds and carburetors, may be cleaned using usual methods (e.g., bead blasting, soda blasting, Scotch Brite pads) as long as part dimensions are not altered.
- o. Coatings/Paint:
 1. Unless otherwise restricted within the AS rules, paints and coatings are permitted on drivetrain components except for the following locations: internal engine block surfaces, internal cylinder head surfaces, internal intake manifold surfaces, and internal carburetor surfaces.
2. Engine Cooling System:
 - a. Radiator:
 1. Any radiator may be used, provided it can be mounted in the original location and requires no body or chassis modifications to install.
 2. Catch and/or expansion tanks may be added or substituted.
 3. Engine coolant fluid is unrestricted.
 4. Coolant/heater hoses and clamps may be substituted. Heater hoses may be plugged. Heater water control valve(s) may be added or substituted.
 5. The entire heater assembly may be removed. This includes all hoses, lines, ducts, coils and controls. Any resulting holes in the firewall must be plugged or covered.
 6. Thermostats may be modified, removed, or replaced with blanking sleeves or restrictors.
 7. Screens may be mounted in front of the radiator and/or oil cooler(s) and must be contained within the bodywork.
 - b. Coolers:
 1. Engine and power steering oil cooler(s) may be added or substituted.
 2. Location within the chassis is free, provided that it/they are not mounted within the driver/passenger compartment.
 - c. Cooling Fans:
 1. Any cooling fans may be used. Cooling fans may be removed.
 2. Electrically operated fans with manual or automatic actuation may be fitted.
3. Transmission/Final Drive:
 - a. Transmission:

9.1.6. American Sedan (AS) Specifications

1. Full preparation cars only:
 - a. Any H-Pattern 4 or 5 speed transmission is permitted with the gear ratios listed on the vehicle spec line (with a tolerance of +/- .05 per gear). 4 speed transmissions must match either 4 speed gear ratios listed on their specification line or one of the car's specification line 5 speed gear ratio sets for gears 1 through 4, with a tolerance of +/- .05. Sequential shifting transmissions are prohibited. Pneumatic, hydraulic or electric actuation of the gear shift mechanism is prohibited. Transmissions that use a gear engagement mechanism different than stock type (e.g., circular, beveled) are prohibited. Face-tooth engagement gearboxes (e.g., dog rings) are permitted at an 50 lbs. weight penalty. Any first gear ratio greater than 2.5 is permitted.
 - b. Any conventional H-pattern, non-sequential shifter may be used.
 - c. Transmission mounts are unrestricted.
 - d. Transmission lubricants are unrestricted.
 - e. Transmission coolers are permitted. Dry Sump transmission coolers are not permitted.
 2. Restricted preparation cars only:
 - a. OEM or Factory equivalent transmission components must be utilized. Updating and/or backdating within a specification line is permitted.
 - b. Transmission repair procedures may be performed utilizing OEM procedures.
 - c. Any conventional H-pattern, non-sequential shifter may be used.
 - d. Transmission mounts are unrestricted.
 - e. Transmission lubricants are unrestricted.
 - f. Transmission coolers are permitted. Dry Sump transmission coolers are not permitted.
- b. Driveshaft:
1. Full preparation cars only:
 - a. OEM driveshafts may be replaced with any one piece driveshaft of steel or aluminum construction.
 - b. The driveshaft may be modified to fit alternate differentials and/or transmissions.
 - c. Driveshaft loops are permitted/recommended.
 2. Restricted preparation cars only:
 - a. OEM driveshafts may be replaced with any one piece driveshaft of steel or aluminum construction.
 - b. Driveshaft loops are permitted/recommended.
- c. Rear Axle/Final Drive:
1. Full preparation cars only:
 - a. Any OEM rear axle assembly is permitted, provided it was available in the listed vehicles contained within the specification line.
 - b. Ford 9" rear axles are permitted in all cars. Center section shall be of ferrous material.
 - c. Dana 44 axles are permitted in all cars.
 - d. Any final drive ratio is permitted.
 - e. Any limited slip or locked differential is permitted.
 - f. C-clip eliminators are permitted.
 - g. Full floater axles are permitted.
 - h. Aftermarket or modified rear differential covers are allowed.
 - i. Differential coolers are permitted. Dry Sump differential coolers are not permitted.
 - j. For any rear axle assembly, welding of the rear axle tubes is permitted.
 2. Restricted preparation cars only:
 - a. Any OEM rear axle is permitted, provided it was available in the listed vehicles contained within the specification line.

- b. Any final drive ratio is permitted, provided it fits the allowed stock differential housing without modification to the housing.
 - c. Any limited slip or locked differential is permitted.
 - d. Aftermarket or modified rear differential covers are allowed.
 - e. Aftermarket axle shafts and bearings are allowed
 - f. Differential coolers are permitted. Dry Sump differential coolers are not permitted.
 - g. C-clip eliminators are permitted.
 - h. For any rear axle assembly, welding of the rear axle tubes is permitted.
4. Suspension:
- a. Ride Height- Minimum ride height is five (5) inches, to be measured at the lowest point of the sheet metal rocker panel, but not to include welded seams, stock ground effects cladding, or fasteners.
 - b. Springs and Shock Absorbers:
 - 1. Springs of any origin may be used, provided they are of the same number and type as originally fitted and they must be installed in the original location. Coil over springs and shocks are prohibited, unless fitted as original equipment.
 - 2. Any shock absorbers may be used, provided they attach to the original mounting points on the chassis. The number of shock absorbers shall be the same as stock. Remote reservoir shock absorbers are permitted. The location of the reservoir is unrestricted. No shock absorber may be capable of adjustment from within the cockpit or by any other means, such as, but not limited to, any electronic, computer, or feedback control systems while the car is in motion. Magnetic shocks are not permitted.
 - 3. Strut equipped cars may substitute struts and/or may use any insert. On cars where the strut assembly also serves to locate a spring, the lower spring seat ride height location may be altered from stock. Spacers, including threaded units with adjustable spring seats, may be used.
 - 4. Spacers, including threaded units with adjustable spring seats (weight jacks), may be used with coil springs. If spacers are used, they shall be located on and shall be permanently attached to existing chassis or suspension structure, but shall not serve as a reinforcement to that structure. Material may be removed from the upper or lower spring seat to facilitate installation of the spacers. Material may be removed from the chassis, but not the bodywork, to facilitate adjustment of the spacers.
 - 5. Limiting straps to preclude a spring from becoming dislodged are permitted.
 - c. Suspension Control - Any anti-roll bar(s), traction bar(s) and rear upper control arms or like devices, panhard rod, or watts linkage may be added or substituted, provided its/their installation serves no other purpose. The mounts for these devices may be welded or bolted to the structure of the vehicle. No suspension control mount or component shall be located in the trunk or driver/passenger compartment unless installed by the manufacturer as original equipment. No suspension control component may be capable of adjustment from within the cockpit while the car is in motion.
 - d. Suspension Mounting Points:
 - 1. Cars may adjust camber by the use of eccentric bushings at the lower control arm pivot points, by the use of eccentric bushings at the upper suspension control mounting points, and/or by use of slotted adjusting plates at the upper suspension mounting point. If slotted plates are used, they shall be located on existing chassis structure. Material may be added or removed from the upper suspension mounting point to facilitate installation of adjuster plate.
 - 2. Rear camber shall be no more than 1/2 degree negative per side. If equipped with IRS, rear camber shall be no more than 2 degree negative per side.
 - 3. All forms of suspension may adjust caster by means of shims or eccentric bushings. All cars may adjust caster at the upper suspension mounting point/plate.
 - 4. One (1) stay rod may be fitted between the upper front strut/shock towers. One (1) reinforcement bar may be fitted between each front strut/shock tower and the firewall.
 - 5. Bushing material is unrestricted except that bushing material must be at least as stiff as stock (i.e. equal or higher durometer rating). "Air", foam or other soft materials that render the control arms ineffective, are strictly forbidden. Control arm to spindle/knuckle ball joints must be stock or equivalent replacement. Ball joint may be welded or positively attached. Original unmodified lower control arms (front and rear), and original unmodified front upper control

9.1.6. American Sedan (AS) Specifications

arms must be retained. Pins, keys, or weldment may be used to prevent the rotation of alternate bushings, but may serve no other purpose than that of retaining the bushing in the desired position.

6. Any rubber bump stops may be used, but their chassis mounts, brackets, etc., shall not be altered in any way. Rubber bump stops may be removed.
7. Pick-up points on the rear axle housing may be relocated. The removal and/or replacement of the rear suspension torque arm on GM F-body cars and the upper arm on Ford Mustangs is allowed. Pick-up points, on the chassis, for front and rear lower control arms, shocks and springs, must remain in the original location.
8. The use of offset steering rack bushings is permitted. Any tie rods and tie rod ends may be used. Spindles may be machined so that tapered tie-rod end bolts can be replaced with straight bolts.

5. Brake System:

a. Materials:

1. Brake pads, brake linings, and brake fluid are unrestricted.
2. Brake lines may be replaced with steel lines or Teflon lined metal braided hoses. Lines/hoses may be relocated and may be given additional protection. Brake fittings, adapters, and connectors are unrestricted.
3. Hubs shall be of ferrous material or aluminum.
4. Rotor hat shall be of ferrous material or aluminum and may be part of the hub or rotor.
5. Rotor shall be of ferrous material. Rotor shall be the same diameter and thickness as the standard or alternate listed on the specification line for the vehicle.
6. Mounting brackets shall be of metallic material.
7. Materials may differ from above if OEM hardware is utilized.
8. Brake duct fans are permitted for cooling brakes. They shall perform no other function.

b. Components:

1. Full preparation cars only:
 - a. Air ducts may be fitted to the brakes, provided that they extend in a forward direction only, and that no changes are made in the body/structure for their use.
 - b. Parking brakes, mechanisms, and actuating components may be removed.
 - c. One piece front or rear hub with rotor may be replaced with separate hub, rotor hat, and rotor.
 - d. Front spindles/knuckles may be modified to facilitate mounting of alternate brake calipers. Spindle modifications shall serve no other purpose.
 - e. Any front caliper using four (4) or fewer pistons and using one (1) brake line per caliper is allowed.
 - f. Any rear caliper using four or fewer pistons and using one brake line per caliper is allowed.
 - g. Rear caliper mounting brackets may be substituted.
2. Restricted preparation cars only:
 - a. Air ducts may be fitted to the brakes, provided that they extend in a forward direction only, and that no changes are made in the body/structure for their use.
 - b. Parking brakes, mechanisms, and actuating components may be removed. OEM brake hardware, including knuckle/spindle, caliper, rotor, hub, and associated mounting hardware must be utilized.
 - c. Full Preparation modifications as listed in 9.1.6.D.5.b.1 (Components) may be used with wheel sizes listed in a Restricted Preparation car's specification line. Maximum rotor size for this option (front and rear) is 12.2 inches X 1.27 inches.

c. System Control:

1. Brake system circuitry may be revised.
2. The original master cylinder may be replaced with any single or dual master cylinder (with balance bar).
3. Any pedal assembly, including the throttle pedal, clutch pedal, clutch and brake master cylinder.

ders, mechanical linkage and hydraulic lines, may be used. The pedal assembly, and master cylinders, may be relocated. Firewalls and cowlings may be modified to allow for installation of the pedals and master cylinders. Modification must be the minimum required to complete the installation, and shall not serve any other purpose. Dead pedal/foot rest and heel stop may be added.

4. Any brake booster may be used. The brake booster may be removed. A vacuum reservoir or booster may be added.
5. A brake-bias adjustment cable is permitted.
6. Brake proportioning valves may be used provided that they are of the inline, pressure limiting type.
7. ABS and traction systems must be disabled. It is the responsibility of the competitor to provide proof of system disabling.

6. Wheels/Tires:

a. Wheels:

1. Maximum wheel diameter is 17 inches, unless otherwise indicated within the vehicle specification line.
2. Maximum wheel width is 8 inches, unless indicated within the vehicle specification line.
3. Knockoff or quick change type wheels are prohibited.
4. Track may be changed to accommodate larger tires, provided that there is safe tire/fender/chassis clearance under all conditions of steer, bump, and rebound. Wheel spacers are permitted.
5. Tire tread (that portion of the tire that contacts the ground) shall not protrude beyond the fender opening when viewed from the top perpendicular to the ground.
6. Any wheel stud, bolt, and/or nut is permitted.

b. Tires:

1. Max tire size for all cars is 275, unless indicated within the vehicle specification line.
2. Weight penalty for increased width may be assigned within specification line.
3. Tires must conform to GCR section 9.3 Tires.

7. Body/Structure:

a. Fenders:

1. Fenders and wheel openings shall remain unmodified.
2. It is permitted to roll under or flatten any interior lip on the wheel opening for tire clearance.
3. Cars with plastic/composite fenders may remove any interior wheel opening lip, but the resulting material edge shall be no thinner than the basic fender material thickness.
4. Any non-metallic inner fender liners may be used or removed.

b. Air Dams/Spoilers:

1. A front spoiler/air dam is permitted.
2. The front spoiler/air dam shall not protrude beyond the overall outline of the body when viewed from above perpendicular to the ground.
3. The front spoiler/air dam shall be mounted to the body, and shall extend no higher than four (4) inches above the horizontal centerline of the front wheel hubs. No part of the front spoiler/air dam shall be lower than three (3.0) inches from the ground. OEM (factory) front spoiler/air dam systems are permitted and if mounted in the stock location, have no height restrictions.
4. The front spoiler/air dam shall not extend toward the rear of the car further than the vertical centerline of the front wheel hubs.
5. The front spoiler/air dam shall not cover the normal grille opening(s) at the front of the car.
6. Openings in the front spoiler/air dam are permitted for the purposes of ducting air to the brakes, cooler, and radiator.
7. Rear spoilers or wings shall be as originally fitted or as specifically authorized on the specification line for that vehicle.

c. Bumpers/Fascias:

9.1.6. American Sedan (AS) Specifications

1. Unless authorized in these rules or stated in a spec line, all bumper covers, and metal bumper bars shall not be modified or removed. Bumper absorbing material may be removed.

2. Front parking light assemblies may be removed for ducting of air.

d. Hood/Roof/Trunk/Rear Deck:

1. Hood and trunk pins, clips, or positive action external latches are permitted.

2. Stock hood and trunk latches may be disabled or removed; if so, some positive action external fastening method shall be used.

3. Any hood/trunk hinges may be used. Hood/trunk hinges may be removed.

4. Underhood bracing on stock hoods may be modified or removed.

5. Steel, aluminum, or fiberglass hoods may include a sealed protrusion above the hood's external profile not to exceed 3 inches in height. Otherwise the external profile of the hood shall remain stock.

6. Ram air openings and rear openings must be blocked off to prevent passage of air.

7. Sunroofs, Targa tops, and T-tops are only permitted if installed by the manufacturer of the vehicle. If installed they must be retained on the vehicle, run in the closed position, and securely bolted in place unless the operating rails adequately secure the panel. Glass panels are permitted.

e. Glass:

1. OEM or factory equivalent windshield is required.

2. Side windows (not including the front door windows) and rear/deck glass must be OEM/ equivalent or clear polycarbonate type plastic material having a minimum thickness of 3 mm. Polycarbonate windows must retain the same shape, size and location as OEM and must be securely fastened to the car.

3. Door glass, quarter glass, and side marker assemblies may be removed. Openings left by the removal of side marker assemblies shall be completely closed. Quarter glass (if not removed or replaced with Lexan-type plastic material as noted in 9.1.6.D.7.e.2 , or NACA-ducts per 9.1.6.D.8.a.12) must be OEM or factory equivalent.

4. Windshield defrosters are allowed as long as they serve no other purpose.

5. Any windshield wipers, motors, arms and brackets may be used or removed.

f. Doors:

1. The door window operating mechanism, inner door trim panel, armrest, map pockets, and inside door latch/lock operating mechanism may be removed and the inner door structural panel may be modified or removed.

2. The stock side impact beams may be removed when NASCAR-style door bars are installed. Original door hinges and exterior door handles shall be retained. Doors may be pinned, not bolted.

g. Frame/Subframe:

1. The frame or subframe shall be stock for body used.

2. The front and rear subframes may be tied together (front to rear, without crossing the centerline of the chassis) with subframe connectors consisting of curved or straight steel tubing (round, square, or rectangular section) with a maximum wall thickness of 0.125".

3. Sub frame connectors may be bolted or welded to the subframes. These connectors may extend under the floor or may extend through the floor with the floor completely welded to this member. Seam/stitch welding is permitted.

4. A connector may be added between the left and right front frame rails forward of the front axle centerline.

h. Weather Stripping/Seals:

1. Engine compartment, trunk, hatch, and door rubber seals or weatherstripping may be removed.

i. Repair/Modification:

1. All chassis/structural repair, if performed, shall be in concurrence with factory procedures, specifications, and dimensions.

2. Body repair shall be performed using every reasonable effort to maintain stock body contours,

lips, etc. Any body repair modification having as its purpose increased clearance is prohibited.

3. Unless authorized in this rule set, alteration by adding any materials, such as, but not limited to, tape, stickers, metal, or vinyl, for the purposes of improving aerodynamics is prohibited.
4. The unibody may be deformed or modified to accommodate the installation of components or other modifications allowed by these rules. The rear bulkhead may not be cut to accommodate the installation of traction bars or rear upper control arms or like devices. Deformations or modifications shall perform no other function.
5. All exterior and interior trim, grills, moldings, vents, badges, and screens may be removed. Resulting holes may be covered.

8. Driver/Passenger Compartment:

a. Interior:

1. All seats and seat brackets may be removed.
2. In those automobiles where the rear seat back provides the only solid bulkhead between the driver/passenger compartment and an exposed stock gas tank, a metal bulkhead completely filling the exposed seat back opening shall be installed.
3. In those automobiles where rear seat back removal does not expose the stock gas tank directly to the driver/ passenger compartment, a metal (only) bulkhead is optional.
4. Any steering wheel except wood rimmed types may be used.
5. Any gear shift knob may be used.
6. Gauges and instruments are unrestricted. Any instrument panel may be used.
7. Any interior or exterior mirrors may be used.
8. Sun visors, seat belts and their attaching hardware and bracketry may be removed.
9. Complete removal of interior panels is allowed in all or part.
10. Any removable covers used to cover spare tires, tools, bins, etc., may be removed along with attaching hardware and bracketry.
11. Carpets, mats, and their insulating or attaching materials may be removed from the floor and recesses of the cargo/trunk/spare tire area.
12. Installation of air ducts to direct air to cool the driver is permitted. Air ducts to direct air to cool the driver can be installed behind the a-pillar. Duct and mount cannot exceed 8 inches in height by 12 inches in length. NACA-ducts may be mounted in the side windows or quarter windows.

9. Safety:

a. Restraint Systems:

1. Airbags/passive restraint systems shall be removed.

b. Fuel cells:

1. Full preparation cars only:

- a. Fuel cells are mandatory.
- b. Fuel cell size is not restricted.
- c. Fuel cell shall be located within twelve (12) inches of the original fuel tank location or behind the rear axle.
- d. Additional reinforcement may be added to support the fuel cell.
- e. Floor pan may be modified for installation.

2. Restricted preparation cars only:

- a. Fuel cells are optional. If the original fuel tanks are utilized they must not be modified in any way that might jeopardize their crash worthiness.
- b. Fuel cell size is not restricted.
- c. Fuel cell shall be located within twelve (12) inches of the original fuel tank location or behind the rear axle.
- d. Additional reinforcement may be added to support the fuel cell.
- e. Floor pan may be modified for installation.

9.1.6. American Sedan (AS) Specifications

- c. Headlights:
 - 1. Headlight and headlight operating ancillaries may be removed.
 - 2. All resulting openings shall be covered by solid panels of an alternate material. These covers shall be of the same contour and plane as the original lens.
 - 3. OEM light assemblies (i.e. foglamps, driving lights, etc.) mounted on, in or below the bumper shall be removed. Resulting holes may be closed or used for the purpose of ducting air to the brakes, cooler and or radiator as permitted.
- d. Steering Column:
 - 1. The steering column is unrestricted.
 - 2. A collapsible type steering column is strongly recommended.
 - 3. The driver's normal seated position must not be relocated.
 - 4. Full Preparation cars that have OEM electric steering may remove it.
- e. Roll Cage - All cars must have a roll cage as specified in 9.4 Appendix I - 2007 roll cages, sections: 9.4, 9.4.1 and 9.4.4 GT Roll cages, or Appendix J - 2004 Roll Cage Rules.

10. Miscellaneous:

- a. Hardware/Fasteners:
 - 1. Hardware items (nuts, bolts, etc.) may be replaced by similar items performing the same fastening function(s).
- b. Wiring:
 - 1. Removal of wiring associated with a component which may be removed by these rules is permitted.
 - 2. All non-essential wiring, switches, gauges, horns, flashers, relays, and lights may be removed.
 - 3. Existing wiring may be substituted.

E. CAR CLASSIFICATION

No automatic transmissions, turbochargers/superchargers, or convertibles are permitted in American Sedan. Cars are classified by body style and engine displacement. NOTE: For competition in American Sedan, Full Preparation General Motors products shall be prepared to 1982-1992 Chevrolet Camaro and Pontiac Firebird engine and transmission specifications per current American Sedan Category Specifications. Full Preparation Ford products shall be prepared to the 79-93 Mustang engine and transmission specifications per the current American Sedan Category Specifications.

F. ENGINE BUILD SHEETS (Full Preparation only)

No. of Cylinders: V-8

Bore (Max): 4.040"

Stroke (Max): 3.500"

Compression Ratio: 10.30 Max.

**Piston to Deck Clr: Not to exceed 0.013" above block deck surface
(zero deck)**

Valve Lift: 0.5000" Max. @ 0.0000" lash

Head Casting #'s: see spec lines

BLOCK

Crankshaft Housing Bore: 2.4412-2.6416"

Block Deck Height:

GM: GM: 8.9970"-9.0430"

Ford: 8.1880-8.2240"

Bore Spacing:

GM: 4.4000"

Ford: 4.3800"

Roller bearings of any type are not permitted for the camshaft, rod, or crankshaft bearings.

Options:

- 1. One-piece rear main seal adapter (with seal) may be used.
- 2. Cylinder block oil restrictors may be installed.
- 3. Block may be machined for the purpose of installing cylinder

O-rings.

4. Block may be machined to true warped surfaces.
5. Block casting seam flash may be deburred.
6. Lifter bore sleeving is permitted.
7. A maximum of two cylinders may be sleeved.
8. Steel main bearing caps and four bolt main bearing caps may be fitted provided no other modifications are made to any approved part or specified dimension. Blocks may be machined to accept four bolt bearing caps.

CONNECTING RODS

Big End Bore: 2.2247-2.2398"

Pin Fit: Floating or Interference Fit

Center to Center: 6.00" Max

Material: Forged Steel / Cast Iron (No Billet)

Alternate Manufacturer: Any rod meeting the AS specs is permitted.

Options:

1. Wrist pin oiling holes may be added.

CAMSHAFT

Drive Type: Single or Dual-row chain

Lifter Type: Solid, flat-tappet

Lifter Dia: .8750" nominal

Options:

1. Camshaft thrust button may be installed

CRANKSHAFT

Main Journal Dia (Min): 2.2182"

Rod Journal Dia (Min): 2.0690"

Options:

1. Any commercially available steel crankshaft (cast or forged) which meets approved stroke, journal diameters and other specified dimensions and requirements is permitted. The minimum weight for any steel crankshaft shall be 42 lbs.
2. Crankshaft casting seam flash may be deburred.

PISTON

Material: Aluminum (Cast or Forged)

Ring Configuration: 3 rings, above pin

Dome Configuration: Any dome configuration is permitted.

Pin Diameter: .930" Max

Options:

1. Pins may be centered or offset. Offset shall not exceed factory specifications.

CYLINDER HEADS

Valve Job (Head): Refer to Figure 1

Intake Valve Size (Max): 1.94"

Exhaust Valve Size (Max): 1.55"

Port Volume (Max.): see spec line

Options:

1. Angle milling permitted on head gasket or intake manifold gasket surface(s) only. Modification or machining of exhaust manifold surfaces of cylinder head is prohibited.
2. Intake manifold surface may be milled to match angle milled head.
3. Heads may be machined to accept pushrod guide plates.

9.1.6. American Sedan (AS) Specifications

4. Heads may be machined to accept screw-in rocker studs.
5. Heads may be machined to for the purpose of installing integral o-ring head gaskets.
6. Heat riser passage may be blocked.
7. Valve spring pockets may be machined.

Notes:

1. Absolutely no modification, machining, tooling, etc. of the combustion chambers is permitted.

MISCELLANEOUS

1. Direct replacement high volume/pressure oil pumps may be fitted provided that no modification to the engine is required for their installation. Alternate oil pump drive shafts may be fitted.

G. MEASUREMENT STANDARDS

Measurement standards shall be as specified in Appendix G. with the following exceptions: Wheelbase has a tolerance of $+ 2''/- 1''$.

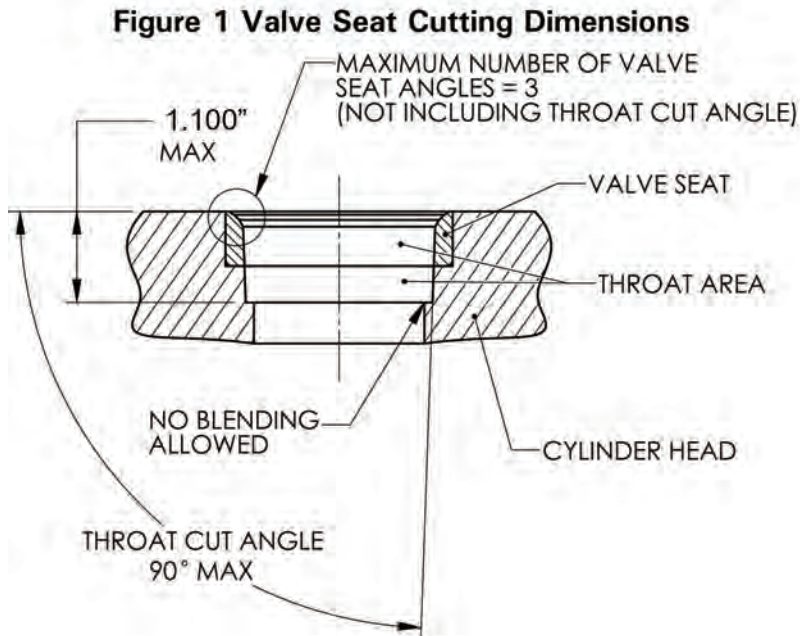
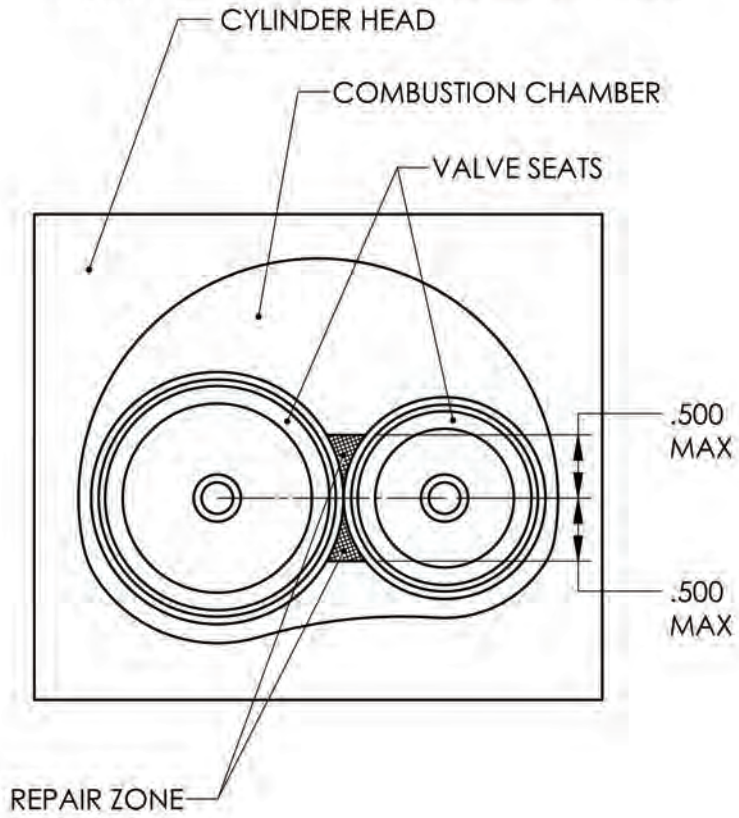

Figure 2 Aluminum Cylinder Head Repair Zone



AS	Wheel-base	Gear Ratios Std. (or Alt.)	Brakes (Max) (in/mm)	Weight (lbs.) (tire sizes are max)	Notes:
Cadillac CTS-V (04-07) Restricted Prep. 5.7L V8 (Aluminum block, Aluminum heads), LS6, 2 valves/cylinder Restricted Prep. 6.0L V8 (Aluminum block, Aluminum heads), LS2, 2 valves/cylinder	113.4	2.97, 2.07, 1.43, 1.00, 0.84, 0.56	(F) 355 Vented Disc (R) 365 Vented Disc	275 Tire: 3420 295 Tire: 3470	GM parts numbers 24255748 (Clutch), 12571611 (Flywheel), and 24237634 (Slave cylinder) may be fitted. Tire Size 295, add 50 lbs. (as noted in weight column). Max. Wheel Size: 18 x 9.5. LS6 engine: Compression Ratio, 10.7:1max; Cylinder Bore, 99 mm; Stroke, 92 mm; Intake Valve Diameter, 50.8; Exhaust Valve Diameter, 39.4 mm; Camshaft Lift @ Lobe, Intake (8.24 mm), Exhaust (8.19 mm); Camshaft Duration at .05 inches valve lift, (Intake, 204 degrees), (Exhaust, 218 degrees); Throttle Body Bore, 75 mm; Rocker Arm Ratio, 1.7:1. (Camshaft Lift tolerance .076 mm) LS2 engine: Compression Ratio, 11.1:1 max; Cylinder Bore, 101.6 mm; Stroke, 92 mm; Intake Valve Diameter, 50.8; Exhaust Valve Diameter, 39.4 mm; Camshaft Lift @ Lobe, Intake (7.78 mm), Exhaust (7.77 mm); Camshaft Duration at .05 inches valve lift, (Intake, 204 degrees), (Exhaust, 211 degrees); Throttle Body Bore, 90 mm; Rocker Arm Ratio, 1.7:1. (Camshaft Lift tolerance .076 mm). Either engine may be used in any car in this specification line, at the appropriate weight. ARE dry sump kit consisting of pump #3021S, Pan 1005M and oil tank 7007-2 or Aviaid dry sump kit #008-10001 consisting of pump 13110-1187, pan 52504-10001 and oil tank 57525 are allowed. Pumps may be driven by a crank mounted, toothed style pulley and belt. Plumbing, hardware, brackets, hoses, and fittings to install above kits are free.
Chevrolet/Pontiac Camaro & Firebird (82-92)	101.0	3.42, 2.28, 1.45, 1.00 or 2.95, 1.94, 1.34, 1.00, 0.73 or 3.35, 1.93, 1.29, 1.00, 0.61	12.2 x 1.27 Disc	3250 Over 313 CID 3550	Engine built to A/S Build Sheet specifications with the following: Head Casting #: 14101081, 14014416 Port Volume (Max.): 081 casting: 170.00 cc IN/65.00 EX; 416 Casting 168.00cc IN/60.00 EX with a 150 lb weight reduction. Edelbrock Cylinder Head Part #s 608979, 608879 are permitted. Camaro only: To aid cooling, the center of the grill opening (license plate area), absorbing material, metal bumper in the resulting open area, and bumper backing may be removed. Alternate gear ratio sets 2.88, 1.91, 1.33, 1.00 or 3.27, 1.98, 1.34, 1.00, 0.68 are permitted. OEM-style ball joints with taller than stock stud lengths are permitted. <i>Upgraded synchros permitted.</i>
Chevrolet/Pontiac Camaro & Firebird (93-02)	101.1	2.95, 1.94, 1.34, 1.00, 0.73 or 3.35, 1.93, 1.29, 1.00, 0.61	12.2 x 1.27 Disc	3250 Over 313 CID 3550	Underside of cowl may be modified to facilitate carb installation. The cowl and shock tower sheet metal may be modified to allow the installation of an 82-92 F-body brake booster and master cylinder. Engine/transmission installation procedure as provided by SCCA Club Racing Technical Department shall be utilized. Engine built to A/S Build Sheet specifications with the following: Head Casting #: 14101081, 14014416; Port Volume (Max.): 081 casting: 170.00 cc IN/65.00 EX; 416 Casting 168.00cc IN/60.00 EX with a 150 lb weight reduction. Edelbrock Cylinder Head Part #s 608979, 608879 are permitted. Alternate gear ratio sets 2.88, 1.91, 1.33, 1.00 or 3.27, 1.98, 1.34, 1.00, 0.68 are permitted. <i>Upgraded synchros permitted.</i>
Chevrolet/Pontiac Camaro & Firebird (93-97) Restricted Prep. 5.7L V-8 (Iron Block, Aluminum Heads) LT1, 2 valves per cylinder	101.1	2.97, 2.07, 1.43, 1.00, 0.80, 0.62 or 3.36, 2.07, 1.35, 1.00, .80, .62	12.2 x 1.27 Disc	3150	Max. Wheel Size: 17 x 9. GM Performance Parts camshaft Kit P/N-12480002 is permitted. 98-02 stock brakes and/or spindles/knuckles may be used. Compression Ratio, 10.6:1 max; Cylinder Bore, 101.6 mm; Stroke, 88.39 mm; Intake Valve Diameter, 49.3; Exhaust Valve Diameter, 38.1 mm; Camshaft Lift @ Lobe, Intake (7.57 mm), Exhaust (7.77 mm); Camshaft Duration at .05 inches valve lift, (Intake, 205 degrees), (Exhaust, 207 degrees); Throttle Body Bore, 48 mm (twin bore); Rocker Arm Ratio, 1.5:1. Camshaft lift tolerance .076 mm. Parts specific to the SS Camaro and Firehawk/WS6 Firebird in the drivetrain/exhaust manifolds/headers/intake manifolds/intake components are not classified in American Sedan. Drivetrain/exhaust manifolds/headers/intake manifolds/intake components manufactured by, but not limited to Street Legal Performance (SLP), Inc., are not permitted. Any commercially available cold air intake that bolts onto the engine is permitted. No modifications to the body, chassis, grill or bumper are permitted when installing a cold air intake.
Chevrolet/Pontiac Camaro & Firebird (98-02) Restricted Prep. 5.7L V-8 (Aluminum Block, Aluminum Heads) LS1, 2 valves per cylinder	101.1	2.66, 1.78, 1.30, 1.00, 0.74, 0.50	12.2 x 1.27 Disc	3250	Max. wheel size: 17 x 9. Compression Ratio, 10.3:1 max; Cylinder Bore, 99 mm; Stroke, 92 mm; Intake Valve Diameter, 50.8; Exhaust Valve Diameter, 39.4 mm; Camshaft Lift @ Lobe, Intake ((98-00), 7.43 mm; (01-02), 6.96 mm), Exhaust ((98-00), 7.43 mm, (01-02), 7.13 mm); Camshaft Duration at .05 inches valve lift, (Intake, (98-00), 202 degrees; (01-02), 197 degrees), (Exhaust, (98-00) 210 degrees; (01-02), 207 degrees); Throttle Body Bore, 75 mm; Rocker Arm Ratio, 1.7:1. Either camshaft may be used for any car in this specification line. Camshaft lift tolerance .076 mm. SLP Intake Lid (SLP part number 21044 (98-99) and 21045 (00-02)) is permitted. Any commercially available cold air intake, including SLP, that bolts onto the engine is permitted. No modifications to the body, chassis, grill or bumper are permitted when installing a cold air intake. All other parts specific to the SS Camaro and Firehawk/WS6 Firebird in the drivetrain/exhaust manifolds/headers/intake manifolds/intake components are not classified in American Sedan. Drivetrain/exhaust manifolds/headers/intake manifolds/intake components manufactured by, but not limited to Street Legal Performance (SLP), Inc., are not permitted.
Chevrolet Camaro SS (V8) (10-13) Restricted Prep. 6.2L V8 (Aluminum Block, Aluminum Heads), 2 valves per cylinder	112.3	3.01, 2.07, 1.43, 1.0, .84, .57	(F) 355 mm X 32.1mm Vented Disc (R) 300 mm X 19.2Vented Disc	275 Tire: 3550 295 Tire: 3600	Max wheel size 20 X 10. 54mm flat plate restrictor required. Compression Ratio, 10.9:1 max; Cylinder Bore, 103.24 mm; Stroke, 92 mm; Intake Valve Diameter, 55.0; Exhaust Valve Diameter, 40.5 mm; Camshaft Lift @ Lobe, Intake (8.24 mm), Exhaust (7.27 mm); Camshaft Duration at .05 inches valve lift, (Intake, 204 degrees), (Exhaust, 211 degrees); Throttle Body Bore, 90 mm; Rocker Arm Ratio, 1.7:1. Camshaft lift tolerance .076 mm. ARE Dry Sump Kit #LS3-3Y permitted.

AS	Wheel-base	Gear Ratios Std. (or Alt.)	Brakes (Max) (in/mm)	Weight (lbs.) (tire sizes are max)	Notes:
Dodge Challenger (08-14) Restricted Preparation 5.7L V8 (Aluminum block, Aluminum heads), 2 valves/cylinder	116.0	2.97, 2.1, 1.46, 1.00, 0.74, 0.50	(F) 360 mm Vented Disc, 32 mm thick (R) 350 mm Vented Disc, 28 mm thick	275 Tire: 3450 295 Tire: 3500	Max. Wheel Size 18 X 10. Stock brakes or alternate Dodge brakes (Part numbers: front caliper (05175106 (R) and 05175107 (L)); rear caliper (R1542564 (R) and R1542565 (L))) may be used with the brake rotor sizes listed in this specification line. Compression Ratio: 9.7:1 max; Cylinder Bore, 3.9170 inches; Stroke, 3.5780 inches; Intake Valve Diameter, 2.050 inches; Exhaust Valve Diameter, 1.550 inches; Camshaft Lift @ Lobe, Intake (12 mm), Exhaust (11.7 mm), Camshaft Duration at .05 inches valve lift, (Intake, 192 degrees), (Exhaust, 196 degrees); Throttle Body Bore, 81 mm; Rocker Arm Ratio, 1.650:1. (Camshaft Lift tolerance .076 mm). Minimum ride height, 4.00 inches. Dodge 1GL20RXF and 82211606 rear spoilers permitted. Dodge 68043390AA air dam permitted.
Ford Mustang Incl. Cobra & Cobra R (79-93)	100.4	3.07, 1.72, 1.00, 0.70 or 2.95, 1.94, 1.34, 1.00, 0.63 or 3.35, 1.99, 1.33, 1.00, 0.68	12.2 x 1.27 Disc	3150 Over 313 CID 3450	Engine built to A/S Build Sheet specifications with the following: Head Casting #: F3ZE AA (GT40), F1ZE-AA (GT-40), F77E-AA (GT-40P), Port Volume (Max.): 143.00cc IN/54.00cc EX (GT-40 & GT-40P) with a 150 lb weight reduction. Edelbrock Cylinder Head Part #s 602579, 602479 are permitted. Alternate gear ratio sets 2.88, 1.91, 1.33, 1.00 or 3.27, 1.98, 1.34, 1.00, 0.68 are permitted. OEM-style ball joints with taller than stock stud lengths are permitted.
Ford Mustang Incl. Cobra thru 95 (94-98)	101.3	2.95, 1.94, 1.34, 1.00, 0.63 or 3.35, 1.99, 1.33, 1.00, 0.68	12.2 x 1.27 Disc	3250 Over 313 CID 3550	Hydro boost braking system is not permitted. Engine built to A/S Build Sheet specifications with the following: Head Casting #: F3ZE AA (GT40), F1ZE-AA (GT-40), F77E-AA (GT-40P), Port Volume (Max.): 143.00cc IN/54.00cc EX (GT-40 & GT-40P) with a 150 lb weight reduction. Edelbrock Cylinder Head Part #s 602579, 602479 are permitted. Alternate gear ratio sets 2.88, 1.91, 1.33, 1.00 or 3.27, 1.98, 1.34, 1.00, 0.68 are permitted. OEM-style ball joints with taller than stock stud lengths are permitted.
Ford Mustang Cobra and GT (94-95) Restricted Prep. 5.0L V8 pushrod engine (Iron Block, Iron Heads), 2 valves per cylinder	101.3	3.35, 1.99, 1.33, 1.00, 0.68	(F) 330 Vented Disc (R) 296 Vented Disc	3250	Max. Wheel Size: 17 x 9. 4.00" (bore) X 3.00" (stroke), Compression ratio, 9.2:1 max.; cam lift at lobe, .28" (intake and exhaust); cam lift at valve .45" intake and exhaust). Camshaft lift tolerance .003 inches. OEM-style ball joints with taller than stock stud lengths are permitted.
Ford Mustang Cobra R (1995) Restricted Prep. 5.8L V8 pushrod engine (Iron Block, Iron heads), 2 valves per cylinder	101.3	3.27, 1.98, 1.34, 1.00, 0.68	(F) 330 Vented Disc (R) 296 Vented Disc	3350	Max. Wheel Size: (F)17 x 9 (R)17x10. Replacement exhaust manifolds, or "headers," may be used. Cylinder head mounting flange(s) shall be no thicker than 0.375 inch, and tubing diameter shall be no greater than 1.625 inch O.D., measured at any tube location one (1) inch from the flange to the collector. 4.00" (bore) X 3.00" (stroke), Compression ratio, 9.2:1 max.; Cam lift at lobe, .29" (intake and exhaust); cam lift at valve .48" (intake and exhaust). Camshaft lift tolerance .003 inches. OEM-style ball joints with taller than stock stud lengths are permitted.
Ford Mustang Cobra and GT (96-98) Restricted Prep. GT: 4.6L V8 OHC engine (Iron Block, Aluminum heads), 2 valves per cylinder Cobra: 4.6L dual OHC engine (Aluminum Block, Aluminum Heads), 4 valves per cylinder	101.3	3.37, 1.99, 1.33, 1.00, 0.67	(F) 330 Vented Disc (R) 296 Vented Disc	3200	Max. Wheel Size: 17 x 9. GT: 90.2 mm (bore) and 90.0 mm (stroke); Compression ratio 9.57:1 max; cam lift at lobe, .26" (intake and exhaust), cam lift at valve .48" (intake and exhaust). Cobra: 90.2 mm (bore) and 90.0 mm (stroke); Compression ratio 10.05:1 max; cam lift at valve, .40" intake and exhaust. Either engine may be used in any car in this specification line. Camshaft lift tolerance .003 inches. OEM-style ball joints with taller than stock stud lengths are permitted.
Ford Mustang Cobra (99-02) Restricted Prep. 4.6L dual OHC V8 Aluminum Block, Aluminum Heads), 4 valves per cylinder	101.3	3.37, 1.99, 1.33, 1.00, 0.68	(F) 330 Vented Disc (R) 296 Vented Disc	3250	Max. Wheel Size: 17 x 9. 90.2mm (bore) and 90.0 mm (stroke); Compression ratio, 10.05:1 max; cam lift at valve, .40" (intake and exhaust). Camshaft lift tolerance .003 inches. OEM-style ball joints with taller than stock stud lengths are permitted.

AS	Wheel-base	Gear Ratios Std. (or Alt.)	Brakes (Max) (in/mm)	Weight (lbs.) (tire sizes are max)	Notes:
Ford Mustang Incl. Cobra (99-04)	101.3	2.95, 1.94, 1.34, 1.00, 0.63 or 3.35, 1.99, 1.33, 1.00, 0.68	12.2 x 1.27 Disc	3250 Over 313 CID 3550	Cobra R bodywork and independent rear suspension not permitted. '94-'95 Mustang K-member may be used to facilitate installation of 302 engine. Under no circumstances is the '99-'00 K-member to be modified. Hydro boost braking system is not permitted. Engine built to A/S Build Sheet specifications with the following: Head Casting #s: F3ZE AA (GT40), F1ZE-AA (GT-40), F77E-AA (GT-40P), Port Volume (Max.): 143.00cc IN/54.00cc EX (GT-40 & GT-40P) with a 150 lb weight reduction. Edelbrock Cylinder Head Part #s 602579, 602479 are permitted. Alternate gear ratio sets 2.88, 1.91, 1.33, 1.00 or 3.27, 1.98, 1.34, 1.00, 0.68 are permitted. OEM-style ball joints with taller than stock stud lengths are permitted.
Ford Mustang GT (99-04) Restricted Prep 4.6L V8 OHC engine (Iron Block, Aluminum heads), 2 valves per cylinder	101.3	3.37, 1.99, 1.33, 1.00, 0.68	(F) 276/330 Vented Disc (R) 266 Vented Disc	3200	Max. Wheel Size: 17 X 9. Cold Air Intake allowed. Replacement manifolds, or "headers," may be used. Cylinder head mounting flange(s) shall be no thicker than 0.375 inch, and tubing diameter shall be no greater than 1.625 O.D., measured at any tube location one (1) inch from the flange of the collector. 90.2 mm (bore) and 90.0 mm (stroke); Compression ratio, 9.57:1 max; cam lift at lobe, .28" (intake), .30" (exhaust); cam lift at valve, .51" (intake) and .54" (exhaust). Camshaft lift tolerance .003 inches.
Ford Mustang Mach 1 (03-04) Restricted Prep. 4.6L V8 dual OHC (Aluminum Block, Aluminum Heads), 4 valves per cylinder	101.3	3.38, 2.00, 1.62, 1.27, 1.00, 0.79	(F) 330 Vented Disc (R) 296 Vented Disc	3200	Max. Wheel Size: 17 x 9. 90.2mm (bore) and 90.0 mm (stroke); Compression ratio, 10.05:1 max; cam lift at valve, .40" (intake and exhaust). Camshaft lift tolerance .003 inches. OEM-style ball joints with taller than stock stud lengths are permitted.
Ford Mustang GT (05-14)	107.1	3.38, 2.00, 1.32, 1.00, .675 or 2.95, 1.94, 1.34, 1.00, 0.63	12.2 x 1.27 Disc	3250 Over 313 CID 3550	Engine/transmission installation procedure as provided by SCCA Club Racing Technical Department shall be utilized. Engine built to A/S Build Sheet specifications with the following: Head Casting #s: F3ZE AA (GT40), F1ZE-AA (GT-40), F77E-AA (GT-40P), Port Volume (Max.): 143.00cc IN/54.00cc EX (GT-40 & GT-40P) with a 150 lb weight reduction. Edelbrock Cylinder Head Part #s 602579, 602479 are permitted. Alternate gear ratio sets 2.88, 1.91, 1.33, 1.00 or 3.27, 1.98, 1.34, 1.00, 0.68 are permitted.
Ford Mustang Coupe GT 4.6L OHC (05-10) Restricted Prep. (Aluminum Block, Aluminum Heads), 3 valves per cylinder	107.1	3.38, 2.00, 1.32, 1.00, 0.68	(F) 316/355 Vented Disc (R) 300 Vented Disc	3200	Max. Wheel Size: 18 X 9.5. Stock brakes or alternate Ford 14" Brembo Brake (Ford Racing Kit #M-2300-S) may be used. Cold Air Intake, Ford Racing Part M-9603-M463 is permitted. Replacement exhaust manifolds, or "headers," may be used. Cylinder head mounting flange(s) shall be no thicker than 0.375 inch, and tubing diameter shall be no greater than 1.625 inch O.D., measured at any tube location one (1) inch from the flange to the collector. 90.2mm (bore) and 90.0 mm (stroke); Compression ratio 10.0:1 max; cam lift at lobe .22" (intake and exhaust); .44" at valve (intake and exhaust). Camshaft lift tolerance .003 inches. K&N 69-3523KP cold air intake permitted.
Ford Mustang Coupe GT 5.0L DOHC (11-14) Restricted Prep. (Aluminum Block, Aluminum Heads), 4 valves per cylinder	107.1	3.66, 2.43, 1.69, 1.32, 1.00, 0.65	(F) 335/355 Vented Disc (R) 300 Vented Disc	275 Tire: 3450 295 Tire: 3500	Max. Wheel Size: 18 x 10. Stock brakes or alternate Ford 14" Brembo Brake (Ford Racing Kit #M-2300-S) may be used. 54mm flat plate restrictor required. 92.2 mm (bore) and 92.7 mm (stroke); Compression ratio, 11.2:1 max; cam lift at lobe, .24" (intake) and .22" (exhaust). Camshaft duration at .100 mm valve lift: intake, 260 degrees; exhaust, 263 degrees. Camshaft lift tolerance .003 inches.
Mercury Capri (79-86)	100.4	3.07, 1.72, 1.00, 0.70 or 2.95, 1.94, 1.34, 1.00, 0.63 or 3.35, 1.99, 1.33, 1.00, 0.68	12.2 x 1.27 Disc	3150 Over 313 CID 3450	Engine built to A/S Build Sheet specifications with the following: Head Casting #s: F3ZE AA (GT40), F1ZE-AA (GT-40), F77E-AA (GT-40P), Port Volume (Max.): 143.00cc IN/54.00cc EX (GT-40 & GT-40P) with a 150 lb weight reduction. Edelbrock Cylinder Head Part #s 602579, 602479 are permitted. OEM-style ball joints with taller than stock stud lengths are permitted.

AS	Wheel-base	Gear Ratios Std. (or Alt.)	Brakes (Max) (in/mm)	Weight (lbs.) (tire sizes are max)	Notes:
<p>Pontiac GTO (04-06) Restricted Prep.</p> <p>2004, 5.7L V8(Aluminum Block, Aluminum heads), LS1, 2 valves per cylinder</p> <p>05-06, 6.0L V8 (Aluminum Block, Aluminum heads), LS2, 2 valves per cylinder</p>	109.8	2.97, 2.07, 1.43, 1.00, 0.84, 0.57	(F) 320 Vented Disc (R) 286 Vented Disc	LS1: 3250 LS2: 3300	<p>Max. Wheel Size: 17 x 9.5. Either engine listed permitted for any car classified in this specification line.</p> <p>2004: Compression Ratio, 10.3:1 max; Cylinder Bore, 99 mm; Stroke, 92 mm; Intake Valve Diameter, 50.8; Exhaust Valve Diameter, 39.4 mm; Camshaft Lift @ Lobe, Intake (6.96 mm), Exhaust (7.13 mm); Camshaft Duration at .05 inches valve lift, (Intake, 197 degrees), (Exhaust, 207 degrees); Throttle Body Bore, 75 mm; Rocker Arm Ratio, 1.7:1.</p> <p>05-06: Compression Ratio, 11.1:1 max; Cylinder Bore, 101.6 mm; Stroke, 92 mm; Intake Valve Diameter, 50.8; Exhaust Valve Diameter, 39.4 mm; Camshaft Lift @ Lobe, Intake (7.78 mm), Exhaust (7.77 mm); Camshaft Duration at .05 inches valve lift, (Intake, 204 degrees), (Exhaust, 211 degrees); Throttle Body Bore, 90 mm; Rocker Arm Ratio, 1.7:1. ARE dry sump kit consisting of pump #3021S, Pan 1005M and oil tank 7007-2 or Aviaid dry sump kit #008-10001 consisting of pump 13110-1187, pan 52504-10001 and oil tank 57525 are allowed. Pumps may be driven by a crank mounted, toothed style pulley and belt. Plumbing, hardware, brackets, hoses, and fittings to install above kits are free.</p> <p>Either engine may be used in any car in this specification line. Camshaft lift tolerance is .076 mm.</p>

SCCA **CLUB RACING**

An electronic copy of the 2018 General Competition Rules is available on the SCCA website:

www.scca.com

Sports Car Club of America, Inc.
Club Racing Department
6620 SE Dwight St.
Topeka, Kansas 66619
(800) 770-2055
www.scca.com